

Filling valve 4183

- Dezincification resistant brass
- Male thread 1/2"
- Check valve



Description

Filling valve.

Construction

Angled ball valve in dezincification resistant brass with spring loaded check valve. Connection male thread 1/2". Seals in PTFE, gaskets in NBR and o-rings in EPDM. Key grip. T-handle in aluminium.

Marking

CR, flow direction arrow, company logo.

Maintenance

The ball valve must be operated periodically, two to three times a year.

Technical data

Body	Dezincification resistant brass CW625N
Ball seal	PTFE
Stem gaskets	NBR/NBR
Check valve	POM
O-rings	EPDM/EPDM

Maximum working pressure: 10 bar
 Maximum working temperature: +90°C
 Minimum working temperature: +2°C

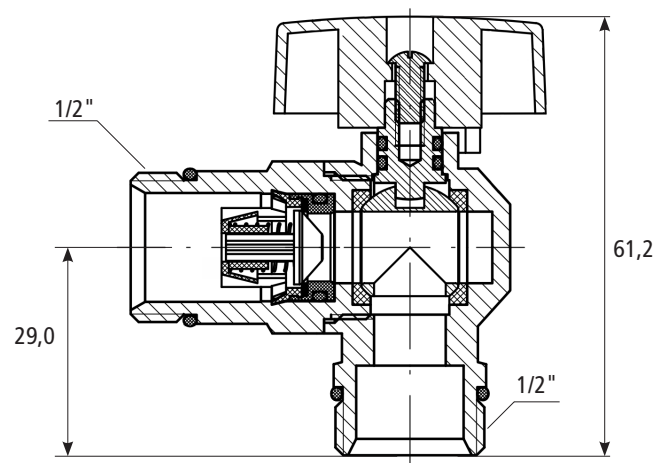

Item number	Description	Connection	Height	Weight (kg per piece)
0441831515	Filling valve 4183-15, 1/2"M, check valve	1/2" M	61,2	0,14

All dimensions in millimetres

Subject to technical changes and corrections without notice